

RoLP LX Wall base

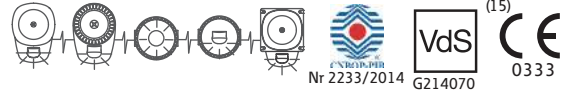

- (EN) EN54-23 Fire alarm devices visual alarm device for use in & around buildings
- (FR) Dispositifs incendie EN54-23 dispositifs visuels alarme feu pour utilisation à l'intérieur et autour des bâtiments
- (DE) EN54-23 Feuermeldevorrichtung Optischer Signalgeber zur Innen-und Aussenmontage
- (PL) EN54-23 Pożarowe urządzenia alarmowe sygnalizatory optyczne do pomieszczeń i na zewnątrz budynków.
- (IT) Dispositivi di allarme antincendio EN54-23 dispositivo di allarme visivo per uso all'interno e nelle vicinanze degli edifici

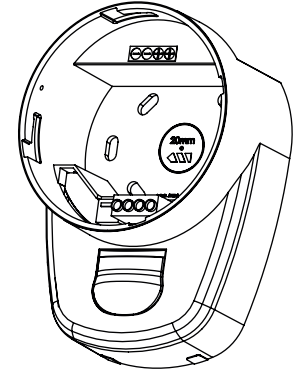

DOP No.: 0333-CPD-075444

	EN54-23:2010		ABS FR & Polycarbonate
	9 - 60Vdc		Type A & B (IP65)
	-25°C ~ +70 °C		1.5W (max)
	2.4m (max)		100mS ON / 900mS OFF 50mS ON / 950mS OFF
	< 120% for 10mS		0.5mm ² - 2.5mm ²

	High Power		Low Power	
	1 Hz	0.5Hz	1 Hz	0.5Hz
	White & Red	W-2.4-7.5 7.5m (135m ³)	White	W-2.2-2.3 2.5m (15m ³)
			Red	W-2.1-2.2 2.5m (15m ³)
	White Flash	12V 51mA 27mA	35mA	19mA
	Flash Blanc	24V 25mA 16mA	16mA	10mA
	Weisser Blitz	48V 18mA 11mA	11mA	9mA
	Red Flash	12V 51mA 27mA	35mA	19mA
	Flash Rouge	24V 25mA 16mA	16mA	10mA
	roter Blitz	48V 18mA 11mA	11mA	9mA

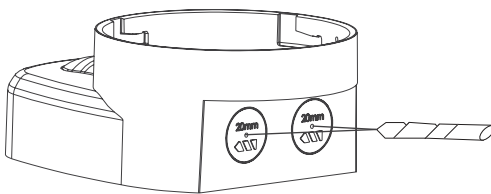
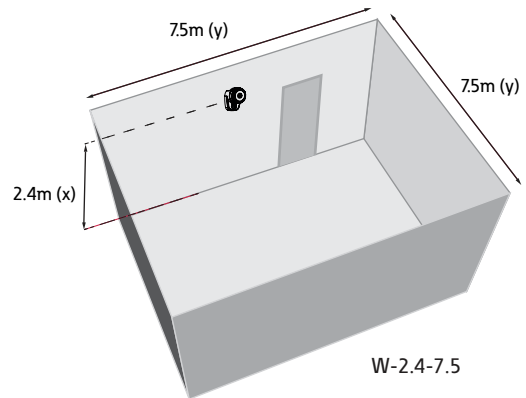

- (EN) Drilling diameter must be adjusted to the diameter of the cable glands.
- (FR) Le diamètre de perçage doit être adapté au diamètre des presses-étoupes.
- (DE) Bohrdurchmesser muss dem Kabeldurchmesser angepasst sein.
- (PL) Średnica wiercenia musi być dostosowana do średnicy dławików kablowych.
- (IT) È necessario adattare il diametro di perforazione in base al diametro del pressacavi.

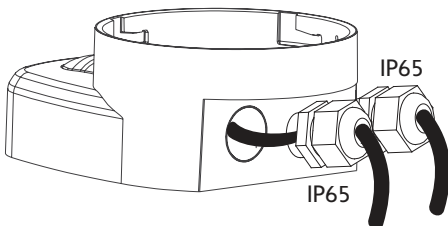

- (EN) Cable glands must be compatible with declared cable size.
- (FR) Les presses-étoupes doivent être adaptés à la section des câbles déclarée.
- (DE) Kabeldurchführungen müssen mit den angegebenen Kabelabmessungen kompatibel sein.
- (PL) Dławiki kablowe muszą pasować do zadeklarowanego rozmiaru kabla.
- (IT) È necessario che i pressacavi siano compatibili con la dimensione del cavo indicata.

Technical data

RoLP LX Wall base

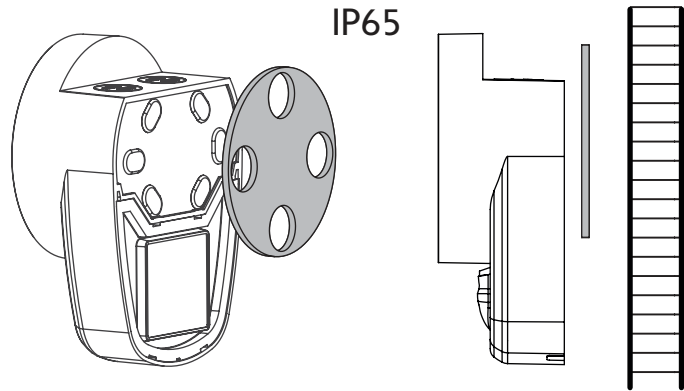
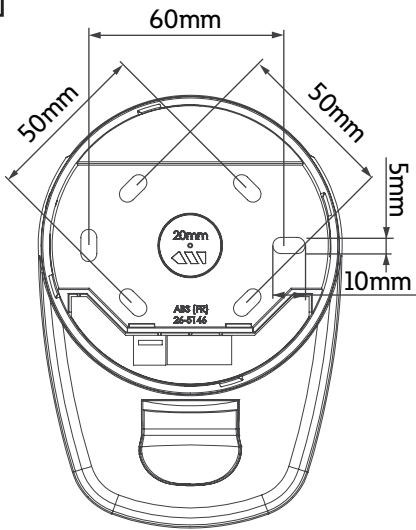

(EN) Place gasket between the product and mounting surface.
 (FR) Placer le joint entre le produit et le support.
 (DE) Die Dichtung zwischen dem Produkt und der Befestigungsplatte.
 (PL) Umieścić uszczelkę między produktem a powierzchnią montażową.
 (IT) Posizionare guarnizione tra il prodotto e la superficie di montaggio.



	1	2	EN54-23
ON	1	0	Pass
1Hz	1	0	Pass
0.5Hz	0	1	Pass
High Power	1	0	Pass
Low Power	0	1	Pass

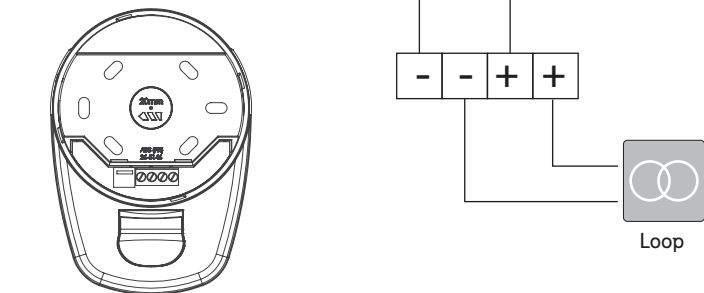
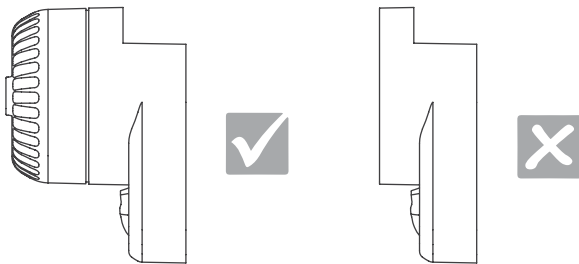
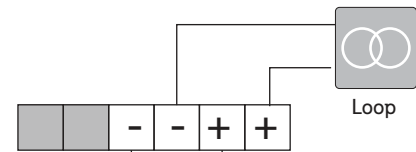
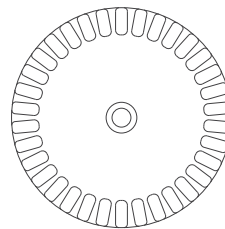

* (EN) Product manual M12-002
 ** (EN) POŻAR label must be applied if product used in Poland
 (PL) Naklejka "POŻAR" musi być użyta jeżeli produkt jest stosowany w Polsce.

Essential Characteristics / Caractéristiques

Operational Reliability / Fiabilité de Fonctionnement

Duration of operation / Durée de fonctionnement	PASS/CONFORME
Provision for external conductors / Disposition pour conducteurs extérieurs	PASS/CONFORME
Flammability of materials / Inflammabilité des matériaux	PASS/CONFORME
Enclosure protection / Indice de protection	PASS/CONFORME
Access / Accès	PASS/CONFORME
Manufacturer's adjustments / Réglages du fabricant	PASS/CONFORME
On-site adjustment of behaviour / Réglages du site	PASS/CONFORME
Requirements for software controlled devices / Exigences relatives aux dispositifs contrôlés par logiciel	PASS/CONFORME

Performance parameters under fire condition / Paramètres de performance en cas d'incendie

Coverage Volume / Volume de couverture	PASS/CONFORME
Variation of light output / Variance de la puissance lumineuse	PASS/CONFORME
Minimum/maximum light intensity / Intensité lumineuse minimale/maximale	PASS/CONFORME
Light colour / Couleur de la lumière	WHITE/RED / BLANC/ROUGE
Light pattern & frequency of flashing / Effets temporels lumineux et fréquence de clignotement du flash	0.5/1Hz
Marking & Data / Marquage et données techniques	PASS/CONFORME
Synchronisation	PASS/CONFORME

Temperature Resistance / Résistance à la température

Dry heat (operational) / Chaleur sèche (fonctionnel)	PASS/CONFORME
Dry heat (endurance) / Chaleur sèche (endurance)	PASS/CONFORME
Cold (operational) / Froid (fonctionnel)	PASS/CONFORME

Humidity Resistance / Résistance à l'humidité

Damp heat, cyclic (operational) / Chaleur humide, cyclique (fonctionnel)	PASS/CONFORME
Damp heat, steady state (endurance) / Chaleur humide, continue (endurance)	PASS/CONFORME
Damp heat, cyclic (endurance) / Chaleur humide, cyclique (endurance)	PASS/CONFORME

Shock & Vibration & Resistance / Choc & Vibration & Resistance

Shock (operational) / Choc mécanique (fonctionnel)	PASS/CONFORME
Impact (operational) / Impact (fonctionnel)	PASS/CONFORME
Vibration (operational) / Vibration (fonctionnel)	PASS/CONFORME
Vibration (endurance)	PASS/CONFORME

Corrosion Resistance / Résistance à la corrosion

SO ₂ corrosion (endurance) / Corrosion par le SO ₂	PASS/CONFORME
--	---------------

Electrical Stability / Stabilité électrique

EMC immunity (operational) / CEM Immunité (fonctionnel)	PASS/CONFORME
---	---------------

Manufactured By

Cooper Fulleon Limited
Llantarnam Park, Cwmbran, Gwent, NP44 3AW, UK
Tel: +44 (0)1633 628 500
Fax: +44 (0)1633 866 346
www.cooperfulleon.com
www.eaton.com
Made in the UK

Eaton Industries Manufacturing GmbH
Electrical Sector EMEA
Route de la Longeraie 7
1110 Morges, Switzerland
Eaton.eu

© 2015 Eaton All rights reserved March 2015



Powering Business Worldwide

ROSHNI (RO) & ROShNI LP (ROLP)



Roshni (RO) : 0832-CPD-0131 (18~28V)
 Roshni LP (ROLP) : 0832-CPD-0128 (9-15V & 18-28V)
 EN54-3 Fire Alarm Device - Sounder
 Dispositif d'alarme incendie EN54-3 – Avertisseur d'incendie
 EN54-3 Feueralarmgerät – Töner
 Dispositivo de alarma anticendio a norma EN54-3 - Sirena
 EN54-3 Brandalarm – sounder
 Dispositivo de alarma de incendios EN54-3 – Timbre de alarma
 EN54-3 Brandvarnare – Signalgivare
 EN54-3 Urządzenie systemów SAP - Sygnalizator

	EN54-3	
	ROLP/Roshni	Roshni
V	9 ~ 15Vdc	18 ~ 28VDC
I	32mA max	35mA
A	0.28mm ² ~ 2.5mm ²	0.75mm ² ~ 2.5mm ² 6A Rating
T	-25 °C ~ +70 °C	-10 °C ~ +55 °C
C	ABS V0	ABS V0
S	S = Type A = (IP54*) D/U = Type B = (IP65*)	IP54 = S IP65 = D/U
M	6	32

*Product exceeds minimum requirements of EN54-3
 See www.fulleon.com
 Le produit dépasse les exigences minimum de EN54-3
 Voir www.fulleon.com
 Das Erzeugnis erfüllt die Mindestanforderungen von EN54-3.
 Siehe www.fulleon.com
 Il prodotto supera i requisiti minimi previsti dalla norma EN54-3
 Vedi www.fulleon.com
 Product overtreft de minimale vereisten van EN54-3.
 Zie www.fulleon.com
 El producto excede los requisitos mínimos de la norma EN54-3
 Véase www.fulleon.com
 Produkten överträffar minsta krav enligt EN54-3
 Se www.fulleon.com
 Parametry techniczne produktu przekraczają minimalne
 wymagania normy PN EN54-3, szczególnie www.fulleon.com

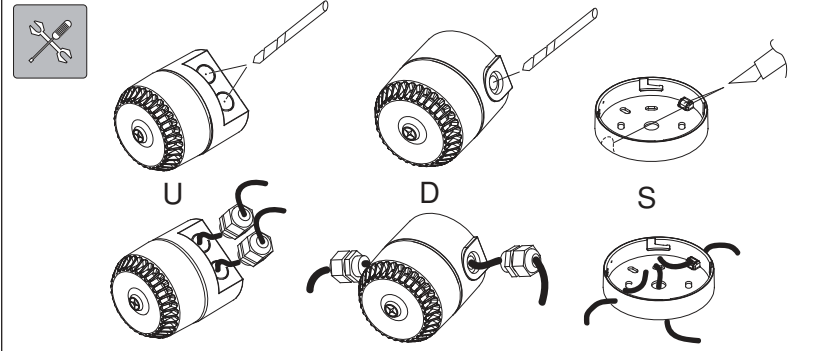
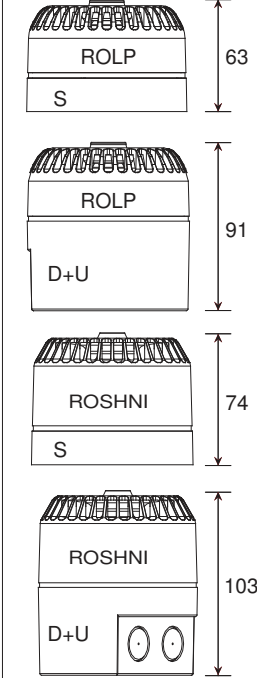
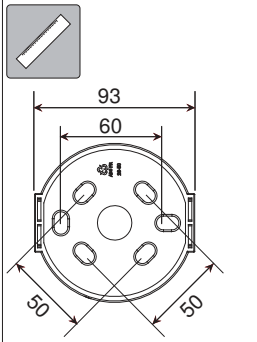

Installation must be in accordance with relevant national wiring regulations or codes for the intended application and voltages employed.
 L'installation doit être conforme à la réglementation ou aux codes nationaux de câblage en vigueur, en vue de l'application désirée et des tensions utilisées.
 Das Gerät ist für die vorgesehene Anwendung und verwendete Spannung gemäß relevanten Bundesvorschriften und Regeln zur Verkabelung zu installieren.
 L'installazione deve essere eseguita in conformità con le disposizioni nazionali vigenti sul cablaggio o i corrispondenti codici per l'applicazione prevista e le tensioni impiegate.
 Installeer moet overeenstemmen met relevante nationale wetgeving of codes voor kabels bij de bedoelde toepassingen en gebruikte voltages.
 La instalación debe estar acorde con las principales normas nacionales para cableado o códigos para la aplicación prevista y los voltajes empleados.
 Installation måste ske i enlighet med landets gällande lagar eller bestämmelser för dragnad av elektriska kablar till den avsedda enheten och den aktuella spänningen.
 Instalacja musi być wykonana zgodnie z obowiązującymi przepisami prawa i wytycznymi zgodnie z pozycjonowaniem sygnalizatora i z wartościami zastosowanych napięć.

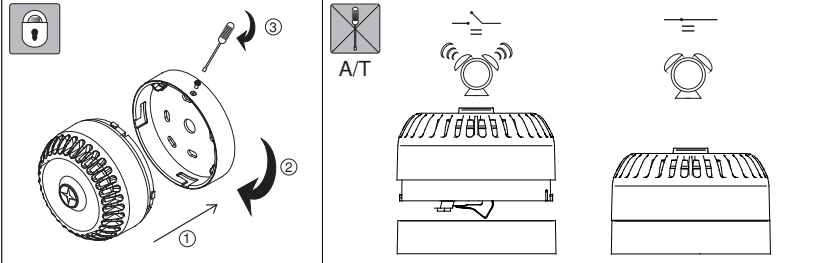
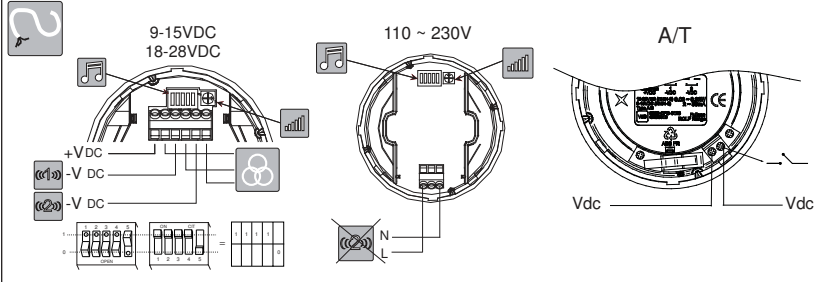

	(1)	(2)	12345	Pattern	Frequency Hz	Rate	Depiction	Main Application	Roshni LP (ROLP)					
									*12Vdc on axis @1M	EN54-3 15Vdc see notes	*24Vdc on axis @1M	EN54-3 28Vdc see notes	mA	dB(A)
1	14	11111	Alternating	800 & 970	2Hz (250ms-250ms)			BS Fire	6	95	*	13	101	*
2	14	11110	Sweep	800 to 970	7Hz (7/s)			BS Fire	8	94	*	12	100	*
3	14	11101	Sweep	800 to 970	1Hz (1/s)			BS Fire	6	95	92	12	102	95
4	14	11100	Continuous	2850	Steady			General Purpose	16	99	*	32	105	*
5	4	11011	Sweep	2400 to 2850	7Hz			General Purpose	16	103	*	32	109	*
6	4	11010	Sweep	2400 to 2850	1Hz			General Purpose	16	105	*	32	112	*
7	14	11001	Slow whoop	500 to 1200	3s sweep, 0.5 s silence, then repeat			Dutch fire (NEN 2575)	6	97	93	12	103	97
8	14	11000	Sweep (DIN)	1200 to 500	1Hz			German fire (DIN 33 404)	7	96	93	15	103	94
9	4	10111	Alternating	2400 & 2850	2Hz (250ms-250ms)			General Purpose	15	99	*	31	105	*
10	14	10110	Intermittent	970	0.5Hz (1s On/1s Off)			PFEER alert	5	95	*	8	101	*
11	14	10101	Alternating	800 & 970	1Hz (500ms-500ms)			BS Fire	6	95	*	12	101	*
12	4	10100	Intermittent	2850	0.5Hz (1s On/1s Off)			General Purpose	9	99	*	17	105	*
13	14	10011	Intermittent	970	0.8Hz (250ms On/1s Off)			General Purpose	3	94	*	5	101	*
14	14	10010	Continuous	970	Steady			PFEER toxic gas	7	95	93	14	101	95
15	14	10001	Alternating	554 & 440	100ms-400ms			French fire (NFS 32-001)	8	96	*	17	102	*
16	16	10000	Intermittent	660	3.3Hz (150ms On/150ms Off)			Swedish (Air Raid)	4	94	*	6	100	*
17	17	01111	Intermittent	660	0.28Hz (1.8s On/1.8s Off)			Swedish (Local warning)	4	95	*	7	101	*
18	18	01110	Intermittent	660	0.05Hz (13s Off / 6.5Hz On)			Swedish (Pre-mess)	3	95	*	6	101	*
19	19	01101	Continuous	660	Steady			Swedish (All clear)	5	95	*	10	101	*
20	20	01100	Alternating	554 & 440	0.5Hz (1s On/1s Off)			Swedish (Turn out)	7	96	*	16	102	*
21	21	01011	Intermittent	660	1Hz (500ms-500ms)			Swedish general purpose	4	94	*	6	101	*
22	14	01010	Intermittent	2850	4Hz (150ms On/100ms Off)			Pelican crossing	12	98	*	27	104	*
23	14	01001	Sweep	800 to 970	50Hz			BS Fire	6	93	*	12	100	*
24	4	01000	Sweep	2400 to 2850	50Hz			General Purpose	15	102	*	32	108	*
25	25	00111	Intermittent	970	3 x 500ms pulses, 1.5s silence, then repeat			ISO 8201	4	95	*	7	101	*
26	26	00110	Intermittent (*)	800 to 970	3 x 500ms pulsed sweep, 1.5s silence, then repeat			ISO 8201	4	95	*	6	102	*
27	27	00101	Intermittent (*)	970 & 800	3 x 500ms pulsed sweep, 1.5s silence, then repeat			ISO 8201	3	94	*	6	101	*
28	10	00100	Alternating	800 & 970	2Hz (250ms-250ms)			BS Fire	6	95	*	12	101	*
29	988Hz	00011	Alternating	990 & 650	2Hz (250ms-250ms) (Symphoni tones)			BS Fire	10	99	93	20	105	96
30	510Hz	00010	Alternating	510 & 610	2Hz (250ms-250ms) (Squashni Micro tones)			BS Fire	8	94	91	16	100	92
31	14	00001	Sweep	300 to 1200	1Hz			General Purpose	10	98	*	14	103	*
32	510Hz	00000	Alternating	510 & 610	1Hz (500ms-500ms)			BS Fire	8	95	*	16	100	*

- (i) Tones certified under the CPD (Fire Alarm Applications) are shown in the column marked EN54-3
- (ii) All other SPL measurements are taken 'on axis' & are not third party verified.
- (iii) Detailed EN54-3 polar SPL measurements are available in M05-004
- (i) Les tons certifiés dans le cadre de la DPC (application alarme incendie) sont indiqués dans la colonne intitulée EN54-3.
- (ii) Toutes les autres mesures NPA sont relevées « sur axe » et ne sont pas vérifiées par un tiers.
- (iii) Les mesures NPA polaires détaillées EN54-3 sont disponibles dans M05-004
- (i) Die nach CPD (Feuermelderanwendung) zertifizierten Töne sind in Spalte EN54-3.
- (ii) Alle anderen Schalldruckmessungen wurden von akustischen Mittelpunkt ab gelesen und von keiner unabhängigen Stelle verifiziert.
- (iii) Detaillierte Polar-SPL-Messungen gemäß EN54-3 sind erhältlich in M05-004
- (i) I toni della sirena certificati CPD (applicazione allarme anticendio) sono indicate nella colonna contrassegnata con EN54-3.
- (ii) Tutte le altre misurazioni SPL sono state rilevate "sull'asse" e non sono state verificate da terzi.
- (iii) Le misurazioni SPL polari ai sensi della norma EN54-3 sono disponibili in M05-004
- (i) U vindt tonen die onder CPD (brandalarmtoepassing) zijn gecertificeerd, in de kolom waar EN54-3 staat vermeld.
- (ii) Alle andere SPL-afmetingen zijn via de 'as' gedaan en niet door derden geverifieerd.
- (iii) Uitgebreide polaire SPL-afmetingen voor EN54-3 zijn beschikbaar in M05-004

- (i) Los sonidos certificados por el CPD (aplicación para alarmas de incendios) se muestran en la columna marcada con EN54-3.
- (ii) Cualquier otra medida del SPL (nivel de intensidad acústica) se toma "sobre el eje" y no está verificada por terceras partes.
- (iii) Las medidas detalladas del SPL polar EN54-3 están disponibles en M05-004
- (i) Signaler som är certifierade för CPD (brandvarnare) visas i kolumnen märkt EN54-3.
- (ii) Alla övriga mätningar av ljudtrycket har genomförts "direkt intill" och är inte bekräftade av tredje part.
- (iii) Detaljerade polära mätningar av ljudtrycket enligt EN54-3 finns under M05-004
- (i) Sygnaly tonowe zgodne z certyfikatem CPD dla systemów sygnalizacji pożaru wskazane są w kolumnie EN54-3.
- (ii) Wszystkie pomiary SPL są wykonane w osi sygnalizatora i nie były poddane weryfikacji przez inną stronę.
- (iii) Szczegółowe katywnych SPL wg EN54-3 dostępne są w M05-004.

CE marking under the CPD was affixed on: (see batch code on product)
 La marque CE dans le cadre de la DPC a été apposée le : (voir code de lot sur le produit)
 CE-Kennzeichnung unter dem CPD angebracht am: (siehe Chargencode am Erzeugnis).
 La marcatura CE ai sensi della direttiva CPD è stata apposta su: (vedi codice sul prodotto)
 CE-markering onder CPD is toegevoegd d.d.: (zie batchcode op het product)
 CE-märkning enligt CPD fästes på: (se satskod på produkten)
 Oznakowanie CE i CPD zostało naniesione na produkt.
 Fulleon Ltd, Cwmbran, South Wales, U.K.
www.fulleon.com